

Driver

- self made LED fixtures
- easy to use
- low cost
- dimming options
- battery supply
- CV supply



Futuro Lighting *design*

LED Driver 150V

96% efficiency typical

Build your own LED fixture

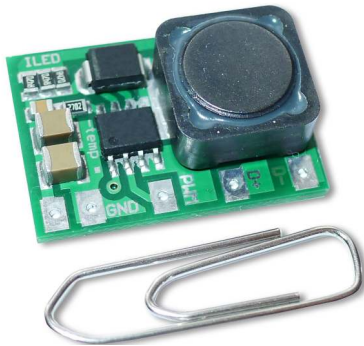

Specification:
 Topology: Buck
 $V_{cc} = 4,5-60\text{ V DC}$
 $I_{LED} = \text{Adjustable}$
 see next page for settings

Regulation / dimming:
 - typical 3% output accuracy
 - soft start capability (just adding cap to PWM in)
 - high speed PWM 20kHz max
 - analog 0,7 - 2,5 V
 - thermal foldback

Switching freq: 1 MHz max
 R_{sense} ratio: 0,15 Ohm / 1 A
 Dimensions: 25 x 18 x 7 mm
 Weight: 4,8 gram
 Over temperature protection
 Over current protection

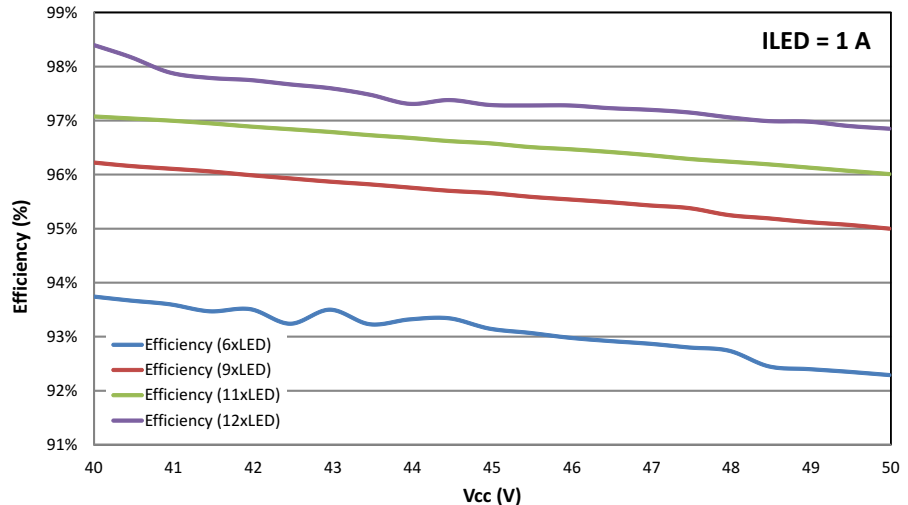
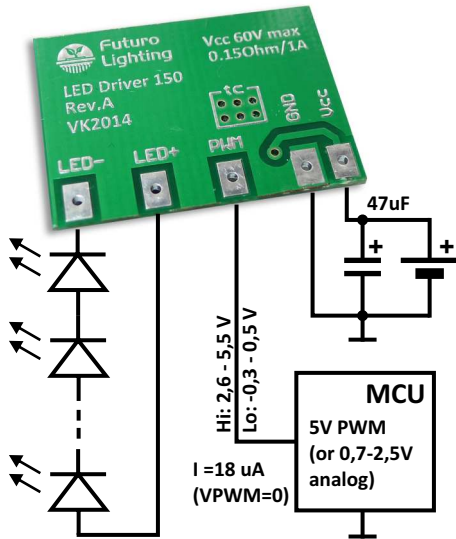

Note: if PWM is not connected max ILED generated
 Options: encapsulation, reverse protection, thermal foldback, MCPCB support



LED Driver 150V

LED current setting

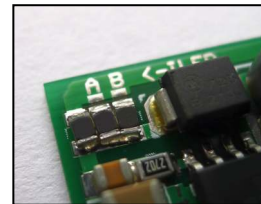
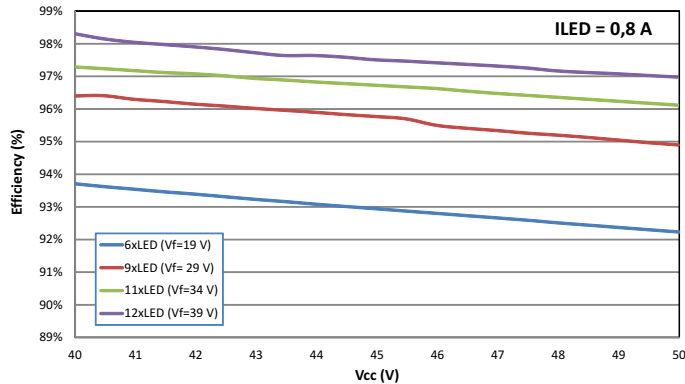
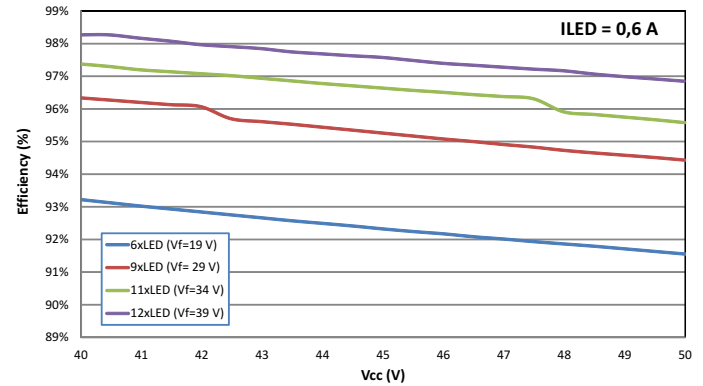
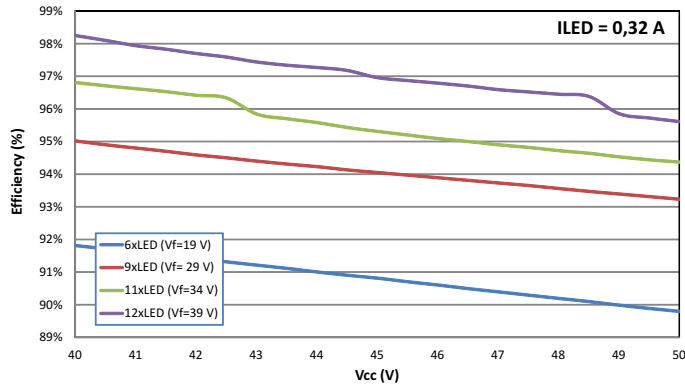

ILED	A	B
0,32 A	-	-
0,6 A	X	-
0,8 A	-	X
1 A	X	X

X - linked by soldering iron

Note: Vin is limited to 55 V max for 0,32 A mode

LED Driver 150V

Thermal foldback

Application Example

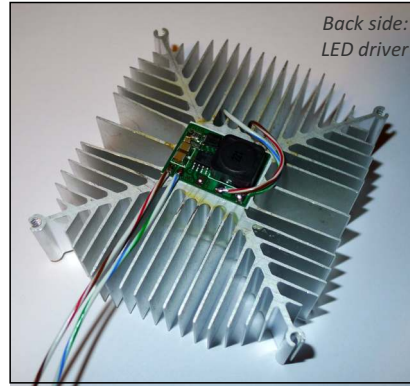
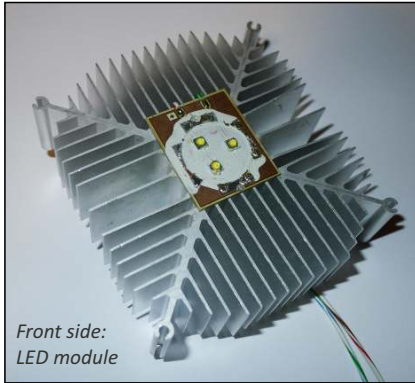

Connecting back side of LED driver to fixture heatsink will protect LED fixture against overheating thus extending LED life time and provide safe fixture operation even for inappropriate installations.

Thermal foldback is temperature of the module is set to ~80°C

thermal connection can be done by appropriate thermo conductive both side tape or glue.

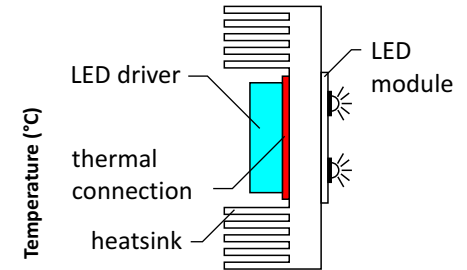
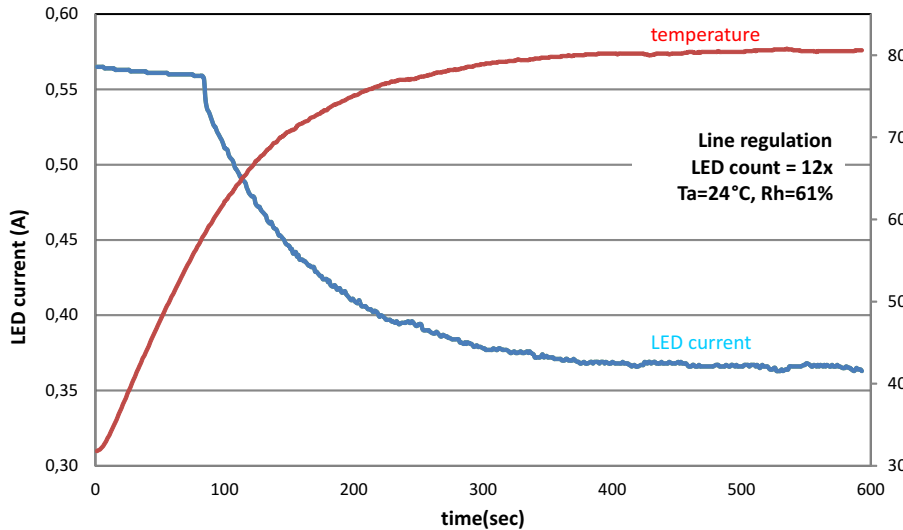

LED Driver 150V

Analog Dimming example (local)

Appropriate for local dimming (Potentiometer close to Driver)

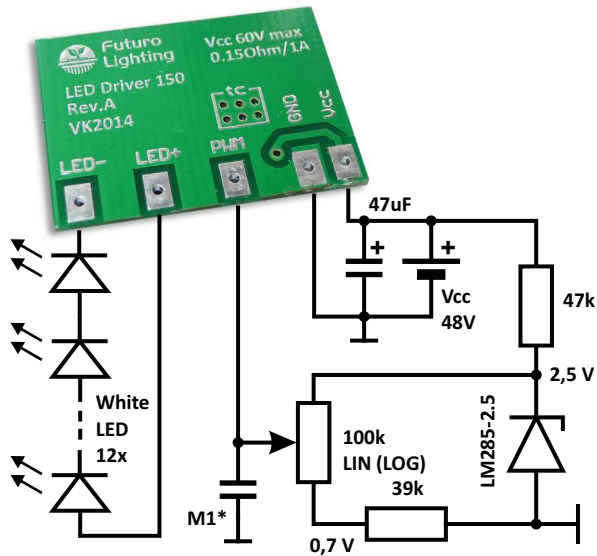

* soft start capacitor

Potentiometer selection:

LIN - linear for linear dimming change

LOG - logarithmic change, more appropriate for human eye response

Literature:

<http://www.ti.com/lit/ds/symlink/lm385b-2.5.pdf>

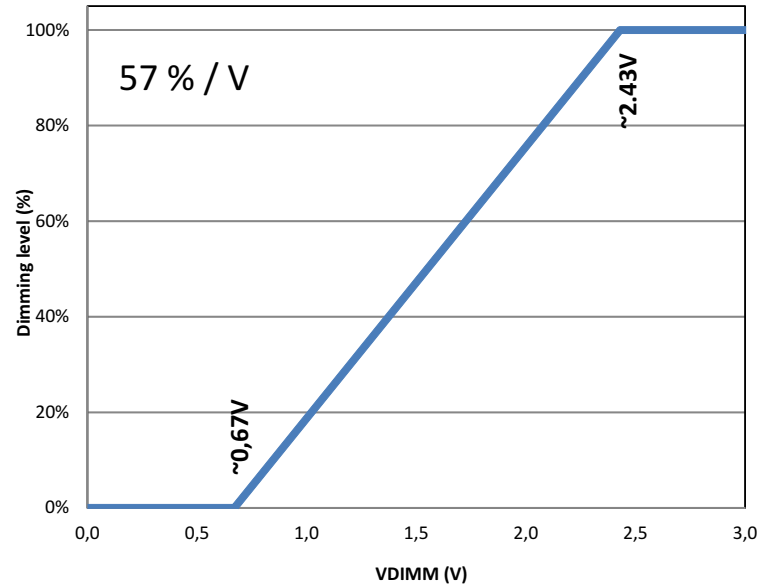

LED Driver 150V

Analog Dimming example (remote)

Appropriate for remote dimming (1-10V dimmer)

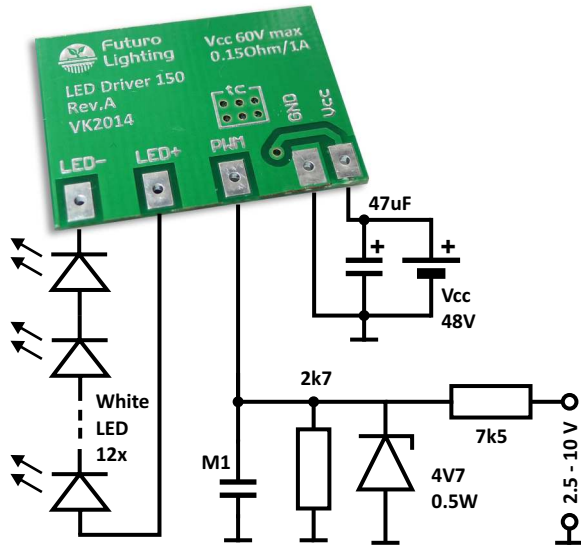

M1 soft start capacitor

Signal selection:

LIN - linear for linear dimming change

LOG - logarithmic change, more appropriate for human eye response

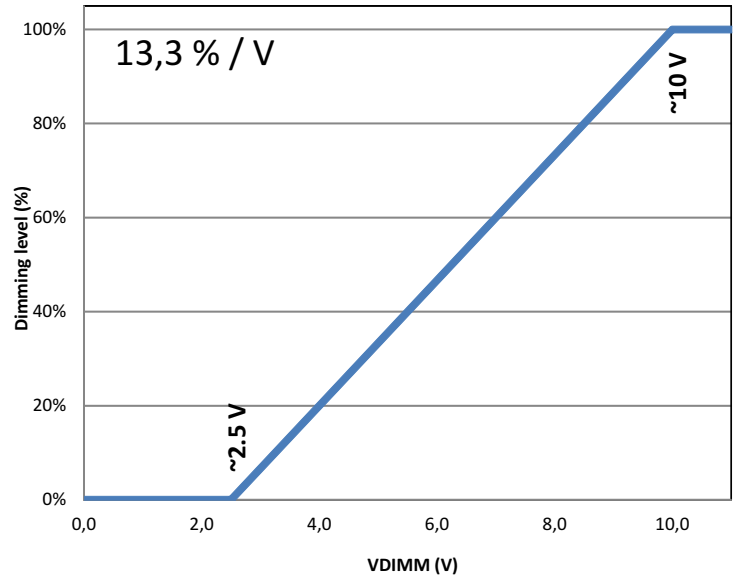

3-CH Digital dimmer for LED Driver 150V

Ready made solution for your lighting needs



Specification:

Supply voltage 30-60 V DC

Power consumption: 1,2 W max

Model: Custom for LED Driver 150

Output voltage 0,55 - 2,55 VDC

Output current: 20 mA / channel max

Number of dimm steps: 250

Illumination: Front - Side Blue LED

End of range indication: blink (Blue)

Power-up fade-in duration: 30 sec

Setting memory type: EEPROM

Dimensions: 85 x 85 x 30 mm

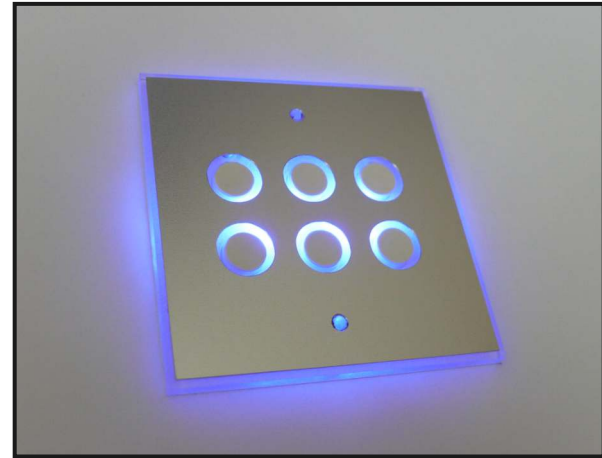
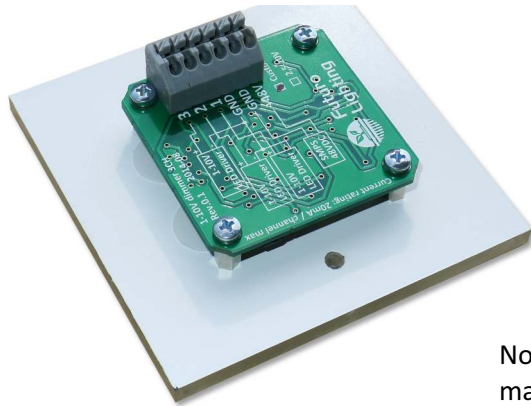

Note: Implemented non isolated buck driver may generate audible noise, this is regular behaving

AquaTimer & LED Driver 150V *Artificial sun for Aquarium life*

Application example

Available as bare PCB or end user product
3D model on request

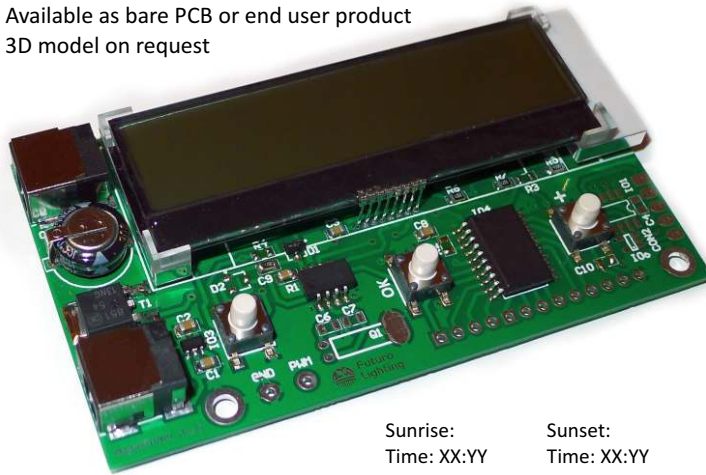

Specification:

Supply Voltage: 6-25 VDC
 Supply current: <15 mA
 Power consumption: 0,65 W max
 Clock source: RTC 24h
 Settings for sunset and sunrise:
 Start time XX:YY
 Intensity 0-100%
 Dimm time: 5-99 minutes

PWM frequency: 2000 Hz
 Resolution: 1000 steps
 Output: 5V / 10mA
 Output: CV, 4A max

Display: 2x16 lines
 Actual time, status,
 intensity, Menu
 Illuminated (white)

Dimensions: 87x50x10 mm

Others:

- Reverse protection
- >3 days clock backup

Sunrise:	Sunset:
Time: XX:YY	Time: XX:YY
P = 10-100%	P = 0-90%
Dimm = 5-99	Dimm = 5-99

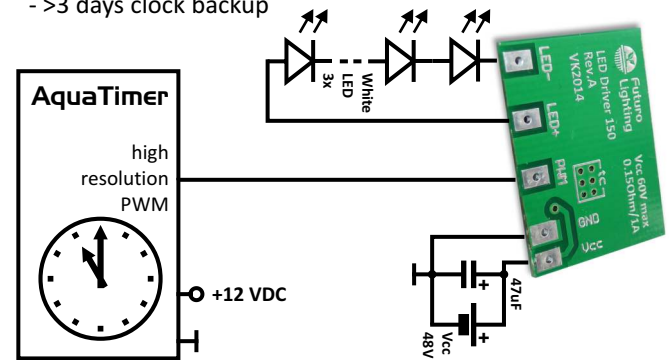
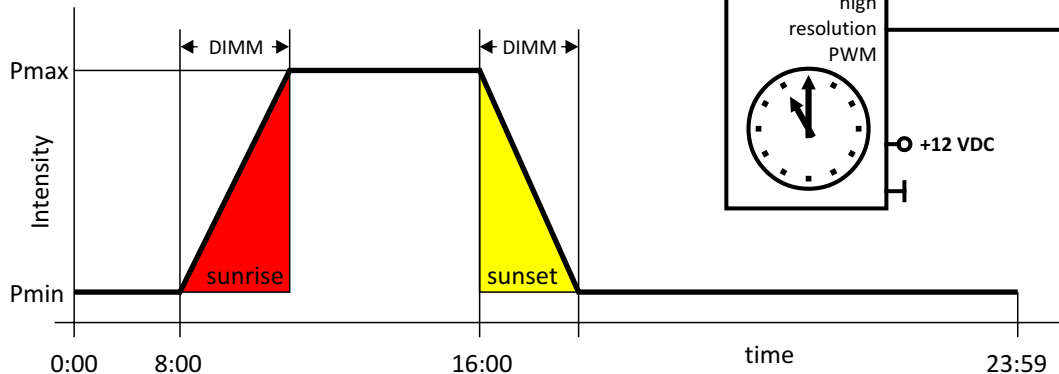

TouchDIMM & LED Driver 150V

Just single push to adjust
Application example

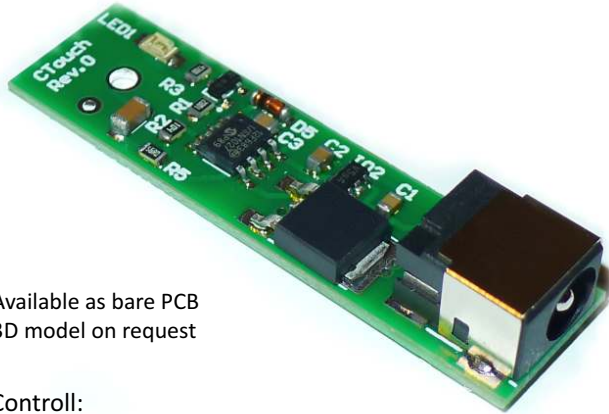

Available as bare PCB
3D model on request

Control:
ON / OFF - short touch (<2sec)



Intensity increase

Touch and hold till reaching required intensity (initial status OFF)



Intensity decrease

Touch and hold till reaching required intensity (initial status ON)



Indicator status

Inactive when off or during fade in and out

Specification:

Supply Voltage: 6-25 VDC

Supply current: <5 mA

Output: PWM / CV 4A max

PWM frequency: 2000 Hz

Resolution: 1000 steps

Output: 5V / 10mA

Dimm steps: 100

Dimming characteristic: Log

Dimensions:

50x13x10 mm

50x13x3.5 mm (wo DC con)

Others:

- Reverse protection
- implemented soft fade in and fade out
- illumination of touch button
- built in N-MOS for CV LED strips

